

VICINITY MAP  
NOT TO SCALE

LEGEND

- CEMENT CONCRETE
- CEMENT CONCRETE TO BE REMOVED
- CMU WALL
- CLF TO REMAIN
- CLF TO BE REMOVED
- PROPERTY LINE
- CENTERLINE
- GRADE CHANGE
- GRADE CONTOUR
- FLOW LINE
- SEWER LINE
- WATER LINE
- GAS LINE
- HOUSE LATERAL
- WATER FEEDER
- GAS FEEDER
- GRADE SPOT ELEVATION

ABBREVIATIONS:

- |                        |        |                          |     |
|------------------------|--------|--------------------------|-----|
| DRIVEWAY               | DWY    | POWER POLE               | PP  |
| SANITARY SEWER MANHOLE | SSMH   | HANDICAP                 | HC  |
| STREET SIGN            | SS     | FRONT OF WALK            | FW  |
| POWER POLE             | PP     | BACK OF WALK             | BW  |
| ASPHALT CONCRETE       | AC     | WATER METER              | WM  |
| CEMENT CONCRETE        | CC     | EDGE OF GUTTER           | EG  |
| WATER VALVE            | WV     | NATURAL GRADE            | NG  |
| EDGE OF PAVEMENT       | EP     | FINISH SURFACE           | FS  |
| TOP OF CURB            | TC     | CONCRETE MASONRY UNIT    | CMU |
| FLOW LINE              | FL     | BEGINNING OF CURB RETURN | BCR |
| TOP OF "X"             | TX     | END OF CURB RETURN       | ECR |
| BOTTOM OF "X"          | BX     | SQUARE FEET              | SF  |
| FIRE HYDRANT           | FH     | TOP OF WALL              | TW  |
| RIGHT-OF-WAY           | R.O.W. | ACRES                    | Ac  |
| CHAIN LINK FENCE       | CLF    |                          |     |

PROPOSED OFF-SITE IMPROVEMENTS

- 1 EXISTING DRIVEWAY TO BE REMOVED
- 2 PROPOSED CURB RAMP TO BE REPLACED EXISTING PER CalTrans REVISED STANDARD PLAN RSP888A (REFER STREET IMPROVEMENT PLANS FOR DETAILS)
- 3 PROPOSED RESIDENTIAL DRIVEWAY W=16, X=3, Y=8 PER CITY OF CARSON STANDARDS. (REFER TO STREET IMPROVEMENT PLANS FOR DETAILS)
- 4 PROPOSED STREET TREES WITH IRRIGATION ALONG 215TH STREET AND MARTIN STREET FRONTING THE SUBJECT PROPERTY PER CITY OF CARSON STANDARDS. (REFER TO STREET IMPROVEMENT PLANS FOR DETAILS)
- 5 PROPOSED STREET LIGHT ON CONCRETE POLE. (REFER TO STREET LIGHTING STANDARDS)
- 6 PROPOSED SEWER LATERAL PER LA COUNTY SANITATION DISTRICT STANDARDS
- 7 PROPOSED WATER FEEDER PER WATER PURVEYOR STANDARDS
- 8 EXISTING ROADWAY PAVEMENT TO BE SLURRY SEALED (CURB TO CURB) ALONG MARTIN STREET AND 215TH STREET FRONTING THE PROPERTY PER CITY OF CARSON STANDARDS. (REFER TO STREET IMPROVEMENT PLANS FOR DETAILS)
- 9 ANY LIFTED OR BROKEN CURB AND GUTTER ALONG MARTIN STREET AND 215TH STREET FRONTING THE SUBJECT PROPERTY TO BE REPAIRED PER CITY OF CARSON STANDARDS. (REFER TO STREET IMPROVEMENT PLANS FOR DETAILS)
- 10 ANY LIFTED OR BROKEN CONCRETE SIDEWALK ALONG MARTIN STREET AND 215TH STREET FRONTING THE SUBJECT PROPERTY TO BE REPAIRED PER CITY OF CARSON STANDARDS. (REFER TO STREET IMPROVEMENT PLANS FOR DETAILS)

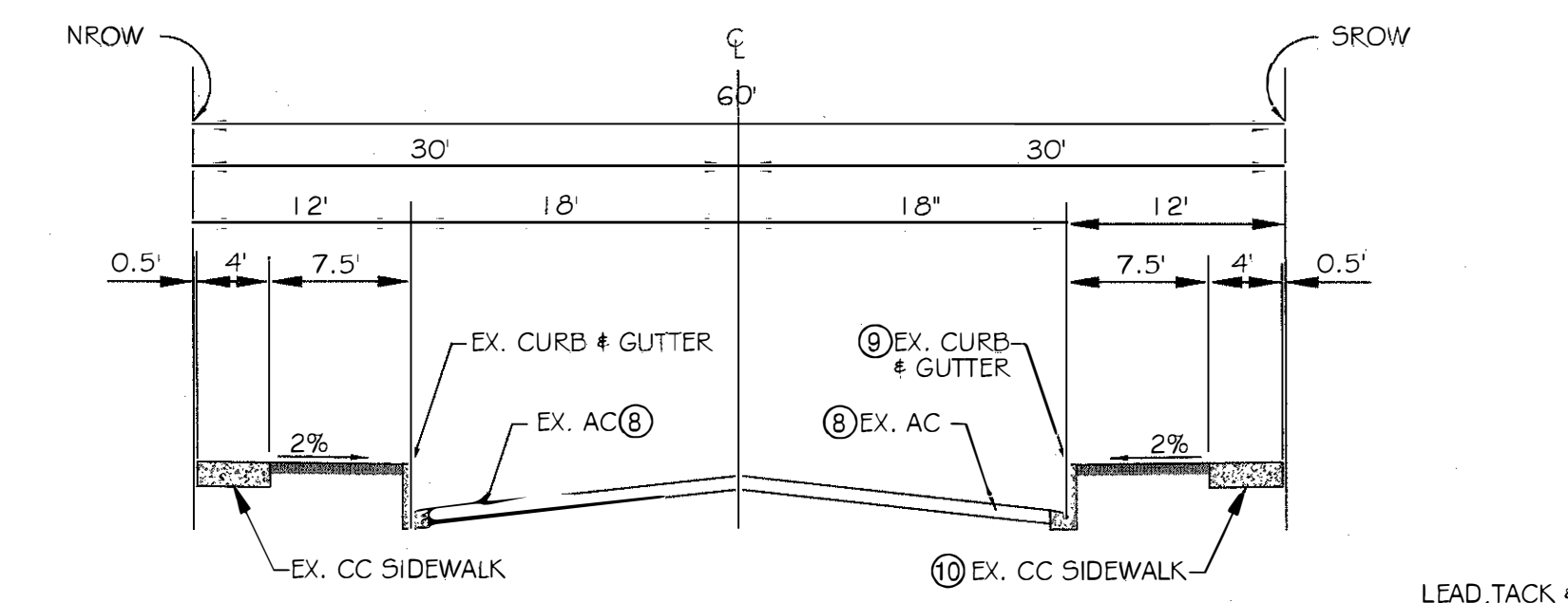

215TH PLACE  
NOT TO SCALE

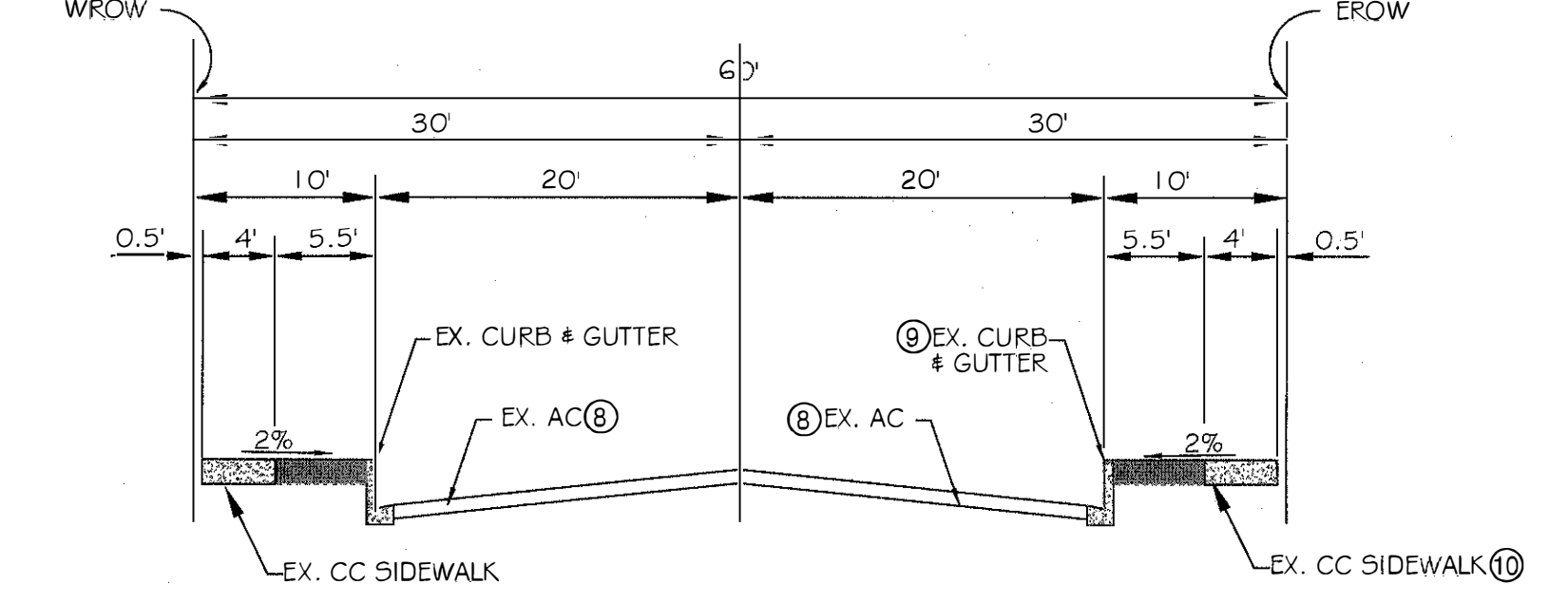

MARTIN STREET  
NOT TO SCALE

TITLE REPORT:

TITLE COMPANY: WESTERN RESOURCES TITLE  
 ORDER NUMBER: 169469 (SH)  
 TITLE OFFICER: GABY HIGERODA  
 PHONE NUMBER: (714) 748-7000  
 EMAIL: TeamGaby@wrtca.com

- AN EASEMENT FOR IRRIGATION DOMESTIC AND INCIDENTAL PURPOSES IN THE DOCUMENT RECORDED IN BOOK 7892, PAGE 124 OF OFFICIAL RECORDS (CAN NOT BE PLOTTED, INDETERMINATE)
- AN EASEMENT FOR CONSTRUCTING AND MAINTAINING A PIPELINE AND WATER DISTRIBUTION SYSTEM AND INCIDENTAL PURPOSES IN THE DOCUMENT RECORDED IN BOOK 1515, PAGE 265 OF OFFICIAL RECORDS (CAN NOT BE PLOTTED, INDETERMINATE)
- AN EASEMENT FOR ROAD AND INCIDENTAL PURPOSES IN THE DOCUMENT RECORDED DECEMBER 10, 1974 AS INSTRUMENT NUMBER 1907 OFFICIAL RECORDS

NOTES:

- THE TERMS AND PROVISIONS CONTAINED IN THE DOCUMENT TITLED "NOTICE OF RESIDENTIAL PROPERTY REPORT REQUIREMENT UNDER CARSON MUNICIPAL CODE, ARTICLE V, CHAPTER 9 RECORDED JANUARY 20, 2017 AS INSTRUMENT NUMBER 40020 OF OFFICIAL RECORDS. (CAN NOT BE PLOTTED, INDETERMINATE)

PURPOSE OF SUBDIVISION:

CREATE FOUR (4) LOTS  
 ZONING: RS1  
 EXISTING: RS1  
 PROPOSED: RS1  
 LAND USE: SINGLE FAMILY RESIDENTIAL  
 EXISTING: SINGLE FAMILY RESIDENTIAL LOTS  
 PROPOSED: 4 SINGLE FAMILY RESIDENTIAL LOTS

AREAS TABULATION

PARCEL	AREA (SQUARE FEET)
1	5980
2	5980
3	6004
4	5250
TOTAL	23214

INDICATES THE BOUNDARY OF THE LAND BEING SURVEYED BY THIS MAP  
 CORNER CUT-OFF ROAD RIGHT OF WAY DEDICATION TO ACCOMMODATE AN AMERICANS WITH DISABILITIES ACT (ADA)-COMPLIANT SPLIT CURB RAMP

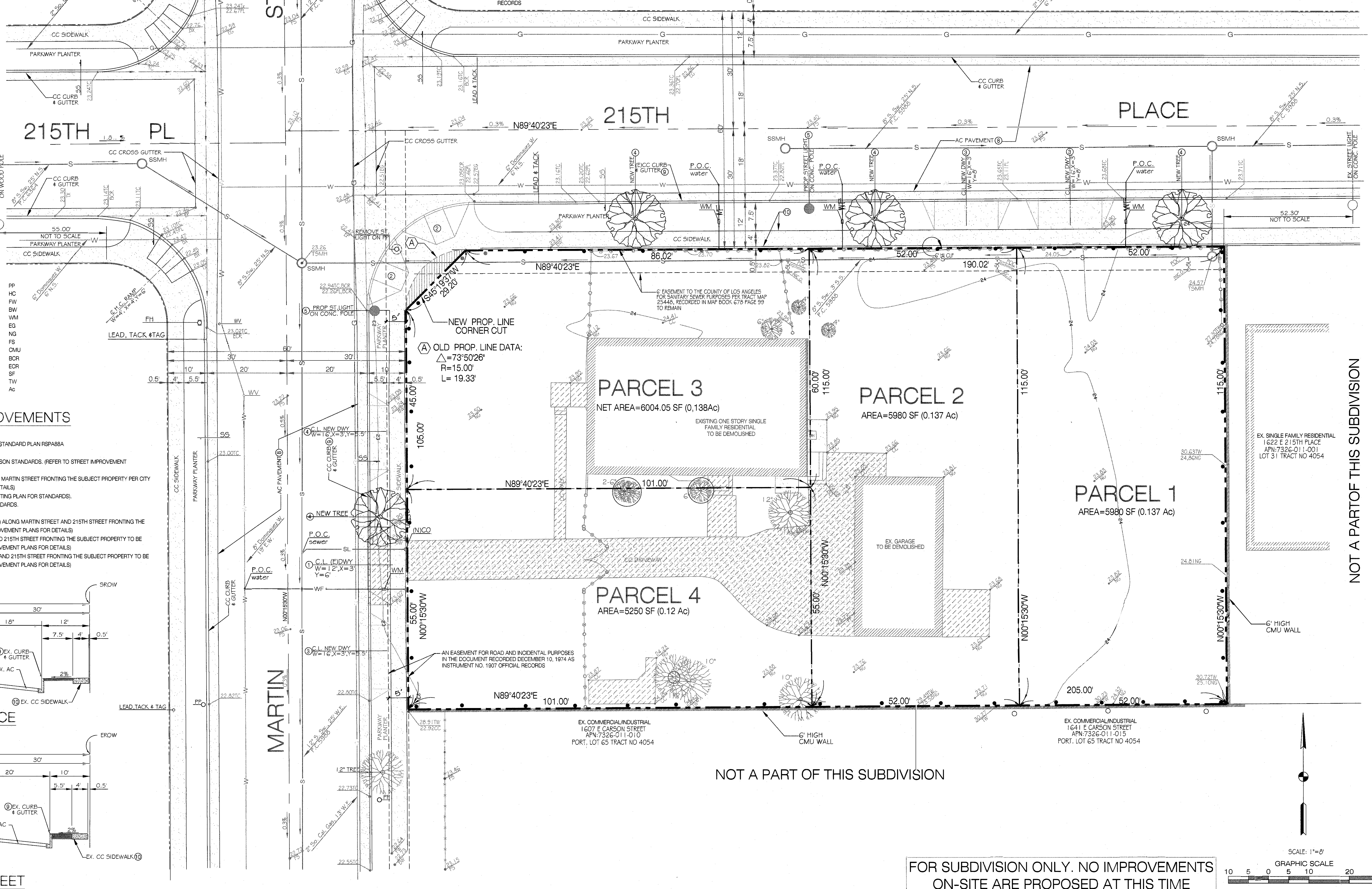

NOT A PART OF THIS SUBDIVISION

NOT A PART OF THIS SUBDIVISION

FOR SUBDIVISION ONLY. NO IMPROVEMENTS ON-SITE ARE PROPOSED AT THIS TIME

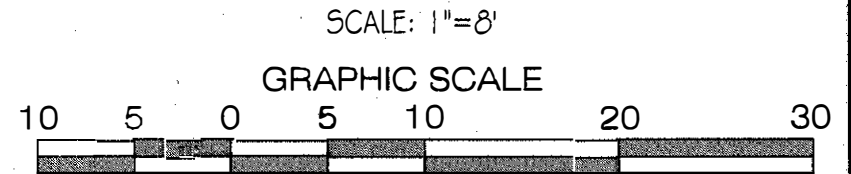

BENCH MARK:  
 NUMBER: 7Y7124 ELEVATION: 24.661 FEET  
 DATE ADJUSTED: 2005 QUAD:  
 DESCRIPTION:  
 RBM TAG IN S CB 300MM(11) EIO BCR @ SE COR CARSON ST & WILMINGTON AVE.  
 LOS ANGELES COUNTY PUBLIC WORKS SURVEY SECTION

UTILITIES:  
 SEWER LOS ANGELES COUNTY, DISTRICT 8  
 WATER CALIFORNIA WATER SERVICE COMPANY  
 POWER EDISON COMPANY  
 GAS SOUTHERN CALIFORNIA GAS COMPANY  
 TELEPHONE AT&T  
 CABLE TELEVISION AT&T/SPECTRUM

PROPERTY OWNERS:  
 KEN SOENG CHEA, TRUSTEE OF KEN SOENG CHEA TRUST AND  
 JENNIFER CHAO, TRUSTEE OF JENNIFER CHAO TRUST  
 21530 215TH STREET  
 CARSON, CALIFORNIA 90745  
 TEL: 562-761-9800  
 ks1001@yahoo.com

LEGAL DESCRIPTION:  
 THE SOUTH 105 FEET OF THE WEST 210 FEET OF LOT 64 OF TRACT NO. 4054, AS PER MAP RECORDED IN BOOK 44, PAGES 39 TO 41 INCLUSIVE OF MAPS IN THE OFFICE OF THE COUNTY RECORDER OF SAID COUNTY.  
 APN: 7326-011-009

CIVIL ENGINEER:  
 RUDDY O. PASCUA  
 2909 W. HELMBA AVENUE  
 ALHAMBRA, CALIFORNIA 91803  
 TEL: 909-513-9435  
 EMAIL: ruddy.pascua1943@gmail.com

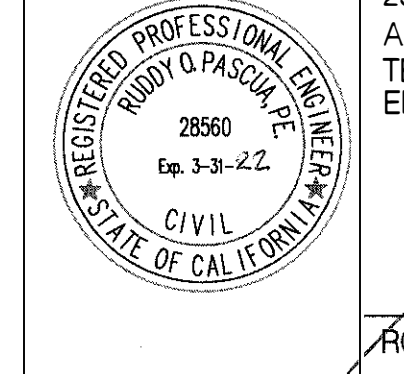

DATE: 6-4-2019

ATTACHMENT NO. 1

MINOR LAND DIVISION  
 TENTATIVE PARCEL MAP 82990  
 CITY OF CARSON, COUNTY OF LOS ANGELES  
 STATE OF CALIFORNIA

BEING A SUBDIVISION OF THE SOUTH 105 FEET OF THE WEST 210 FEET OF LOT 64 OF TRACT NO. 4054 AS PER MAP RECORDED IN BOOK 44, PAGES 39-41 INCLUSIVE OF MAPS IN THE OFFICE OF THE COUNTY RECORDER, OF LOS ANGELES COUNTY

OCTOBER 2019

1"=10'

TPM