

NOTES:

1. SEE STANDARD DRAWING NO. 115 FOR SIDEWALK DESIGNATIONS.
2. WHERE RAISED MEDIAN IS REQUIRED, SEE STANDARD DRAWING NO. 120.
3. PAVEMENT THICKNESS & BASE REQUIREMENT TO BE DETERMINED BY SOILS ANALYSIS.
4. SEE STANDARD DRAWING NO. 104 FOR BASE DETAILS.

MAJOR HIGHWAYS

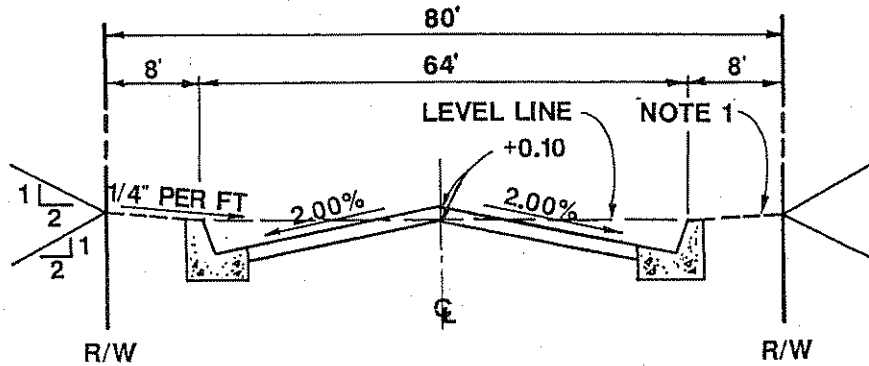

NOTES:

1. SEE STANDARD DRAWING NO. 115 FOR SIDEWALK DESIGNATIONS.
2. PAVEMENT THICKNESS & BASE REQUIREMENT TO BE DETERMINED BY SOILS ANALYSIS.
3. SEE STANDARD DRAWING NO. 104 FOR BASE DETAILS.

SECONDARY HIGHWAYS, INDUSTRIAL & COMMERCIAL STREETS

CITY OF CARSON

REVISIONS	MAJOR & SECONDARY HIGHWAY, INDUSTRIAL & COMMERCIAL STREET SECTIONS	DRAWN BY <i>P. Jacobs</i>
	RECOMMENDED: <i>W. Huber</i> APPROVED: <i>Harold C. Williams</i>	DATE APPROVED <i>2/2/87</i>
	DIVISION ENGINEER DIRECTOR OF PUBLIC WORKS	NO. 100